

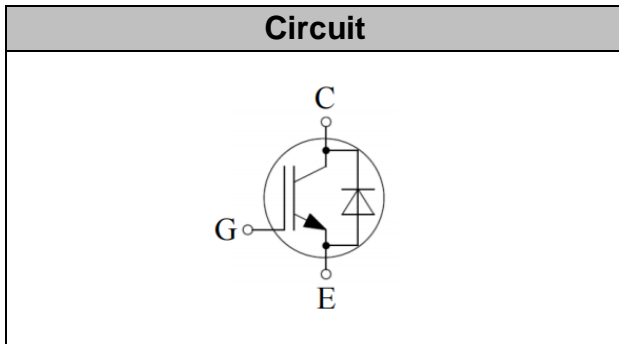

IGBT Discrete

V_{CE}	1200	V
I_C	50	A
$V_{CE(SAT)} I_C=50A$	1.80	V



Applications

- Inverter for motor drive
- AC and DC servo drive amplifier
- Uninterruptible power supply

Features

- High breakdown voltage to 1200V for improved reliability
- Maximum junction temperature 175°C
- Positive temperature coefficient
- Including fast & soft recovery anti-parallel FWD
- High short circuit capability(10us)

Maximum Ratings

Parameter	Symbol	Value	Unit
Collector-Emitter Breakdown Voltage	V_{CE}	1200	V
DC Collector Current, limited by T_{jmax} $T_C=25^{\circ}C$ $T_C=100^{\circ}C$	I_C	85 50	A
Diode Forward Current, limited by T_{jmax} $T_C=25^{\circ}C$ $T_C=100^{\circ}C$	I_F	85 50	A
Continuous Gate-Emitter Voltage	V_{GE}	± 20	V
Transient Gate-Emitter Voltage ($t_p \leq 10\mu s, D < 0.010$)	V_{GE}	± 30	V
Turn off Safe Operating Area $V_{CE} \leq 1200V$, $T_j \leq 150^{\circ}C$		200	A
Pulsed Collector Current, $V_{GE}=15V$, t_p limited by T_{jmax}	I_{CM}	200	A
Diode Pulsed Current, t_p limited by T_{jmax}	I_{Fpuls}	200	A
Short Circuit Withstand Time, $V_{GE}=15V, V_{CC}=600V, V_{CEM} \leq 1200V$	T_{sc}	10	μs
Power Dissipation, $T_j=175^{\circ}C, T_C=25^{\circ}C$	P_{tot}	500	W

Operating Junction Temperature	T_j	-40...+175	°C
Storage Temperature	T_s	-55...+150	°C
Soldering Temperature, wave soldering 1.6mm (0.063in.) from case for 10s		260	°C

Electrical Characteristics of the IGBT ($T_j = 25^\circ\text{C}$ unless otherwise specified):

Parameter	Symbol	Conditions	Min.	Typ.	Max.	Unit
Static						
Collector-Emitter Breakdown Voltage	BV_{CES}	$V_{GE}=0V, I_C=250\mu A$	1200		-	V
Gate Threshold Voltage	$V_{GE(th)}$	$V_{GE}=V_{CE}, I_C=1.4mA$	5.2	5.8	6.5	V
Collector-Emitter Saturation Voltage	$V_{CE(sat)}$	$V_{GE}=15V, I_C=50A$ $T_j=25^\circ\text{C}$, $T_j=125^\circ\text{C}$ $T_j=150^\circ\text{C}$		1.80 2.05 2.15	2.10	V
Zero Gate Voltage Collector Current	I_{CES}	$V_{CE}=1200V, V_{GE}=0V$ $T_j=25^\circ\text{C}$, $T_j=150^\circ\text{C}$			0.25 4	mA
Gate-Emitter Leakage Current	I_{GES}	$V_{CE}=0V, V_{GE}=\pm 20V$			100	nA

Parameter	Symbol	Conditions	Min.	Typ.	Max.	Unit
Dynamic						
Input Capacitance	C_{ies}	$V_{CE}=25V, V_{GE}=0V,$ $f=1MHz$	-	3.09	-	nF
Reverse Transfer Capacitance	C_{res}		-	0.13	-	
Gate Charge	Q_G	$V_{CC}=600V, I_C=50A,$ $V_{GE}=15V$	-	0.24	-	uC

Electrical Characteristics of the Diode (T_j= 25°C unless otherwise specified):

Parameter	Symbol	Conditions	Min.	Typ.	Max.	Unit
Static						
Diode Forward Voltage	V _F	I _F = 50A T _j = 25°C, T _j = 125°C T _j = 150°C		2.10 1.95 1.85	2.70	V

Switching Characteristic, Inductive Load

Parameter	Symbol	Conditions	Min.	Typ.	Max.	Unit
Dynamic , at T_j= 25°C						
Turn-on Delay Time	t _{d(on)}	V _{CC} = 600V, I _C =50A, V _{GE} = -5V~15V, R _g =20Ω	-	23	-	ns
Rise Time	t _r		-	94	-	ns
Turn-on Energy	E _{on}		-	7.31	-	mJ
Turn-off Delay Time	t _{d(off)}		-	226	-	ns
Fall Time	t _f		-	155	-	ns
Turn-off Energy	E _{off}		-	2.93	-	mJ
Dynamic , at T_j= 125°C						
Turn-on Delay Time	t _{d(on)}	V _{CC} = 600V, I _C =50A, V _{GE} = -5V~15V, R _g =20Ω	-	24	-	ns
Rise Time	t _r		-	90	-	ns
Turn-on Energy	E _{on}		-	7.39	-	mJ
Turn-off Delay Time	t _{d(off)}		-	315	-	ns
Fall Time	t _f		-	241	-	ns
Turn-off Energy	E _{off}		-	4.25	-	mJ
Dynamic , at T_j= 150°C						
Turn-on Delay Time	t _{d(on)}	V _{CC} = 600V, I _C =50A, V _{GE} = -5V~15V, R _g =20Ω	-	24	-	ns
Rise Time	t _r		-	89	-	ns
Turn-on Energy	E _{on}		-	7.48	-	mJ
Turn-off Delay Time	t _{d(off)}		-	331	-	ns
Fall Time	t _f		-	285	-	ns
Turn-off Energy	E _{off}		-	4.54	-	mJ

Electrical Characteristics of the DIODE

Parameter	Symbol	Conditions	Min.	Typ.	Max.	Unit
Dynamic , at T_j= 25°C						
Reverse Recovery Current	I _{rr}	I _F =50A, V _R =600V, di/dt= -520A/μs,	-	17	-	A
Diode reverse recovery time	trr		-	547	-	ns
Reverse Recovery Charge	Q _{rr}		-	3.34	-	uC
Reverse Recovery Energy	E _{rec}		-	1.55	-	mJ
Dynamic , at T_j= 125°C						
Reverse Recovery Current	I _{rr}	I _F =50A, V _R =600V, di/dt= -520A/μs,	-	20	-	A
Diode reverse recovery time	trr		-	856	-	ns
Reverse Recovery Charge	Q _{rr}		-	8.11	-	uC
Reverse Recovery Energy	E _{rec}		-	2.88	-	mJ
Dynamic , at T_j= 150°C						
Reverse Recovery Current	I _{rr}	I _F =50A, V _R =600V, di/dt= -520A/μs,	-	24	-	A
Diode reverse recovery time	trr		-	969	-	ns
Reverse Recovery Charge	Q _{rr}		-	9.25	-	uC
Reverse Recovery Energy	E _{rec}		-	3.92	-	mJ

Thermal Resistance

Parameter	Symbol	Max. Value	Unit
IGBT Thermal Resistance, Junction - Case	R _{θ(j-c)}	0.30	K/W
Diode Thermal Resistance, Junction - Case	R _{θ(j-c)}	0.65	K/W
Thermal Resistance, Junction - Ambient	R _{θ(j-a)}	40	K/W

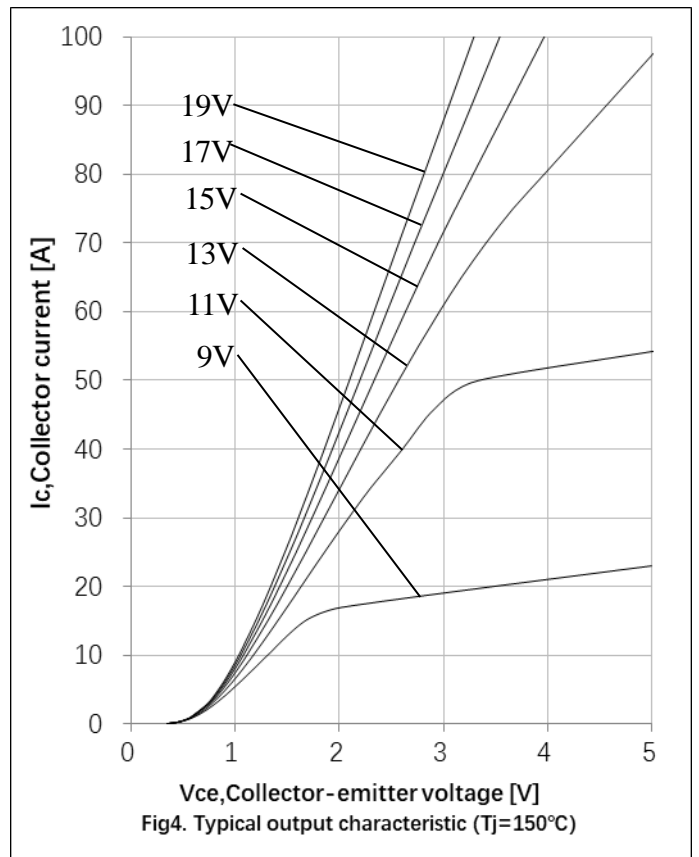
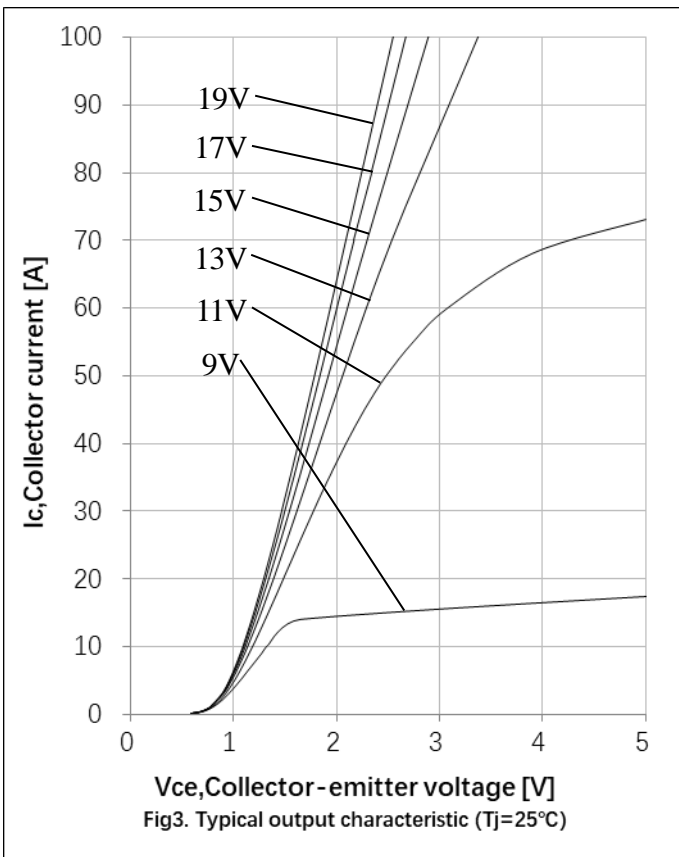
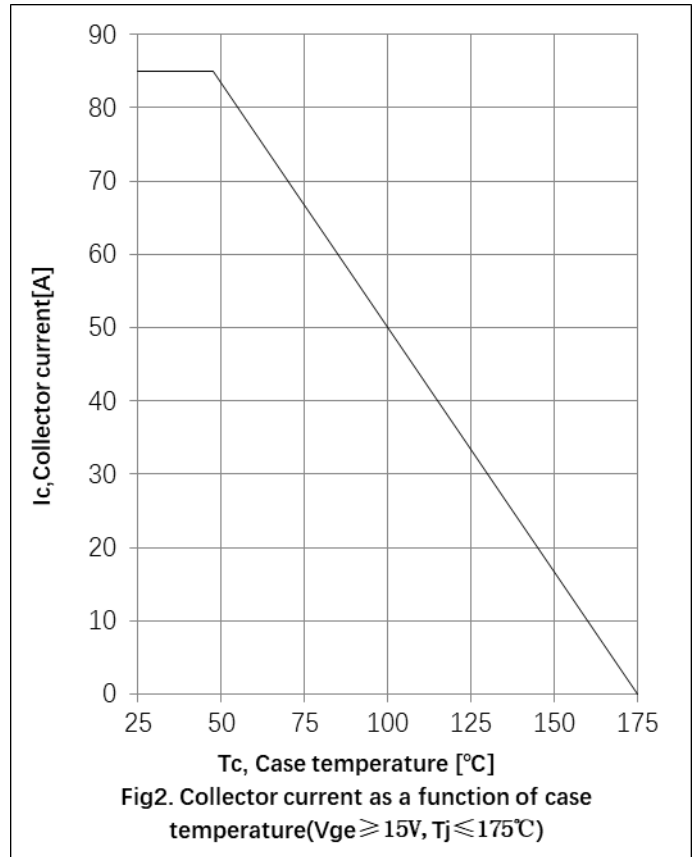
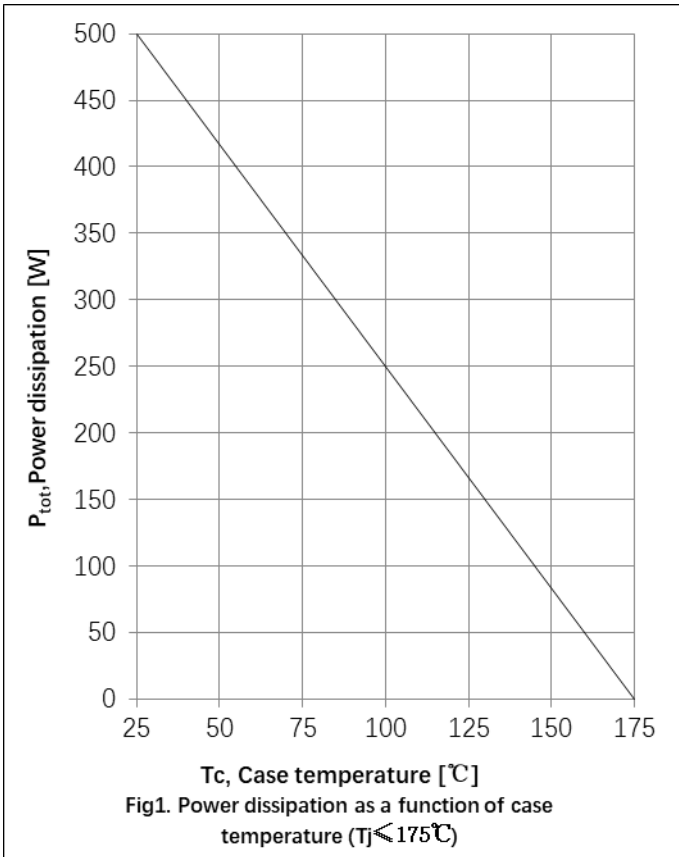

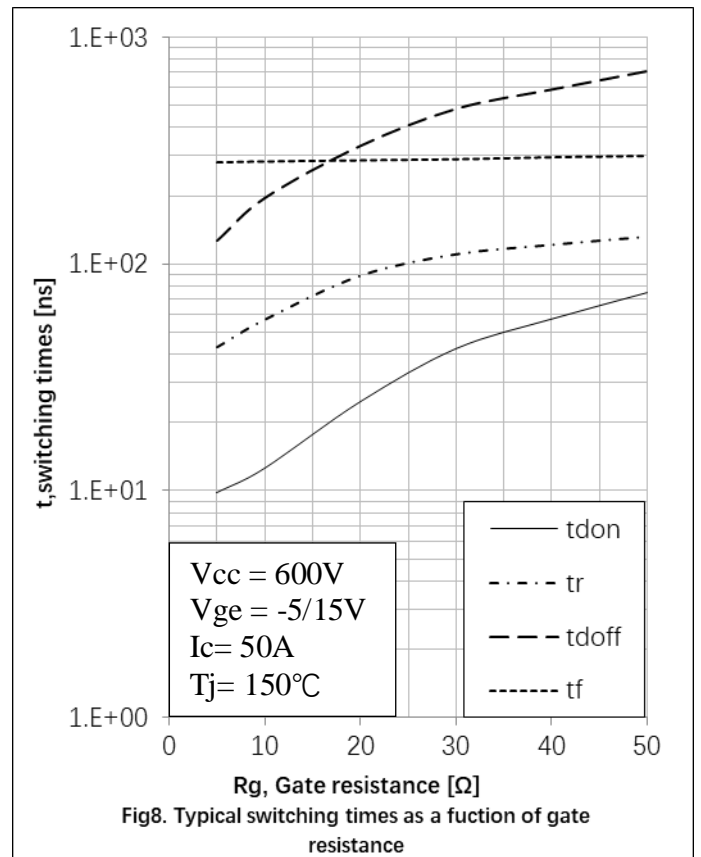
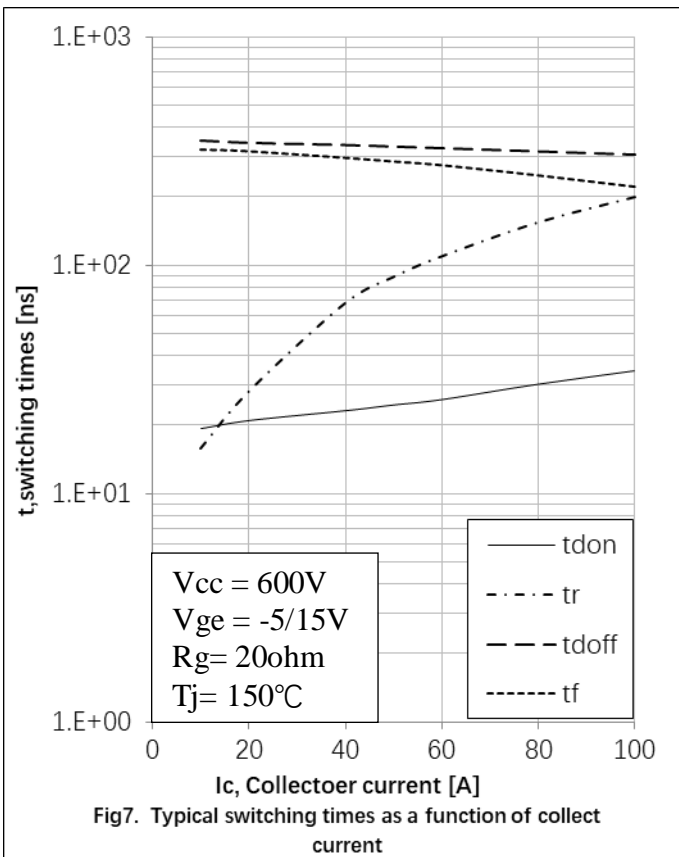
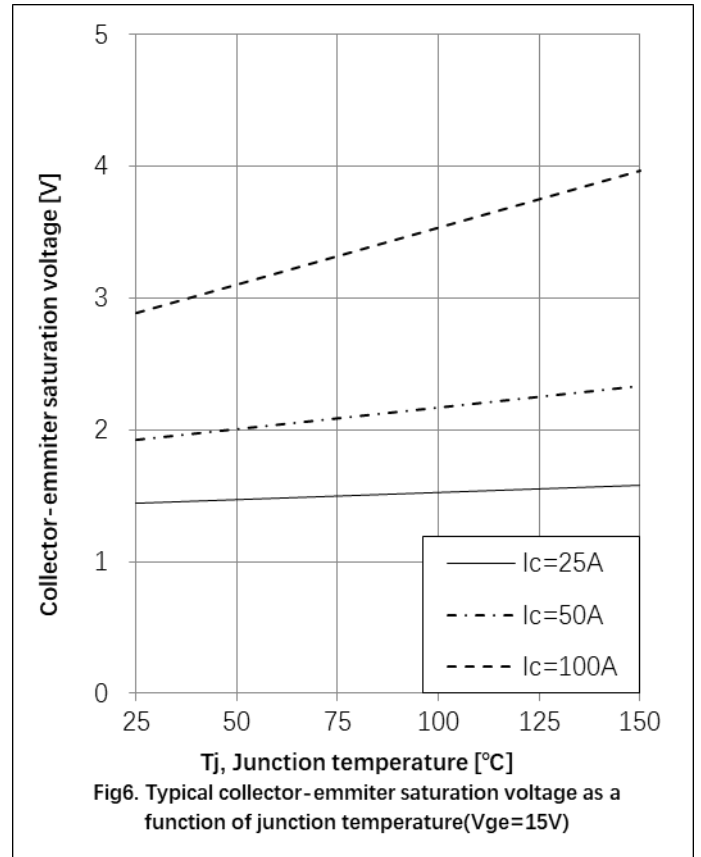
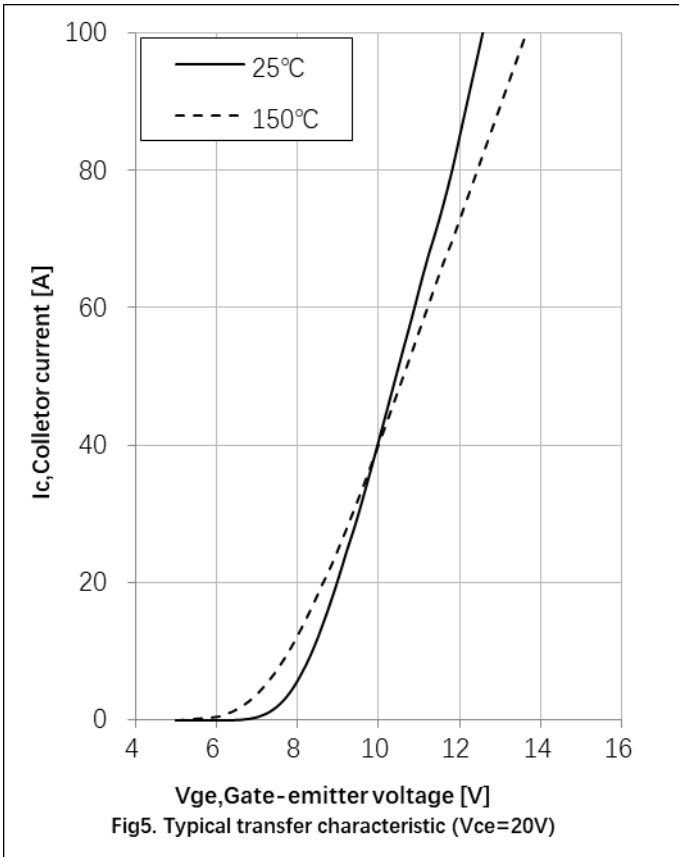

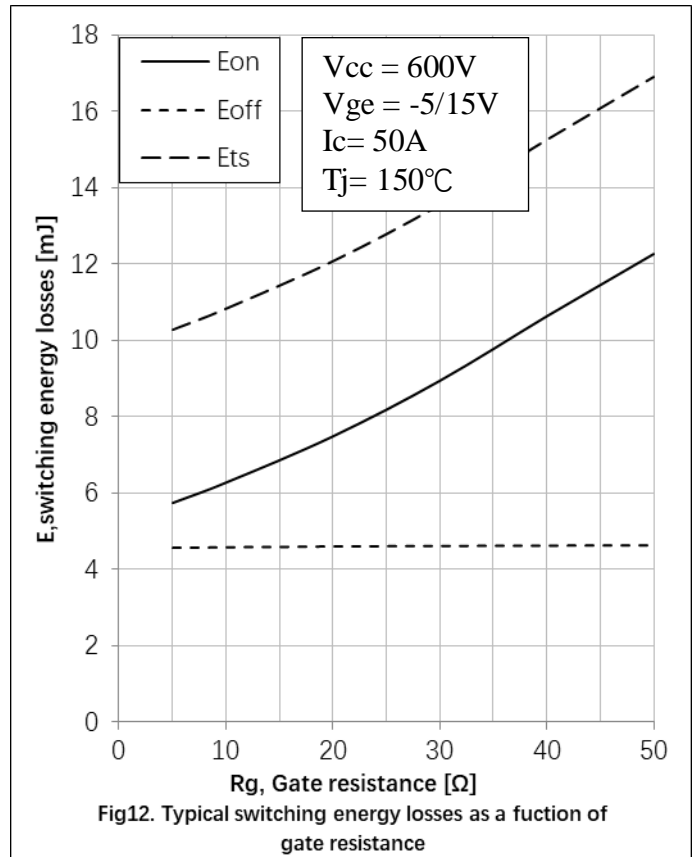
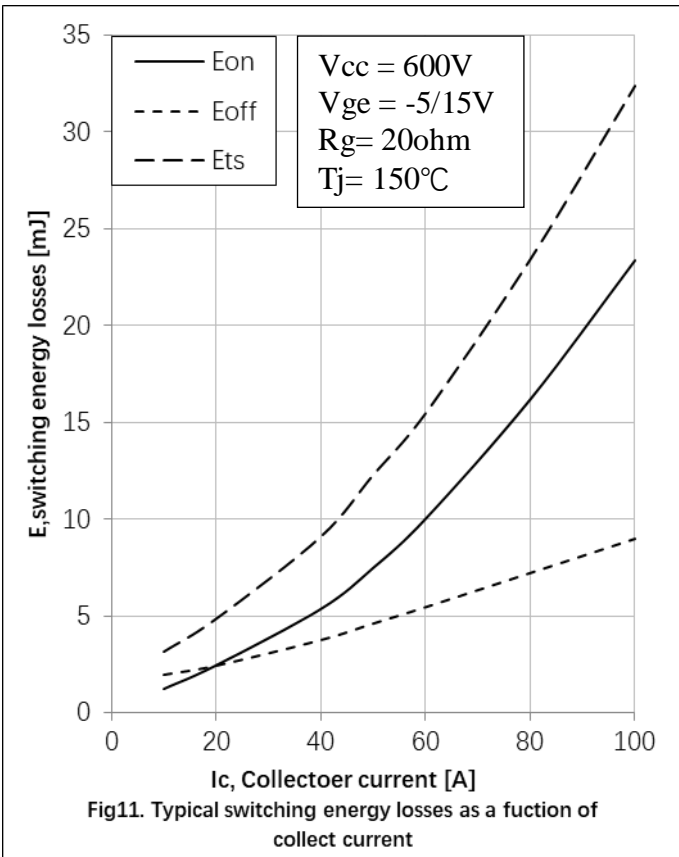
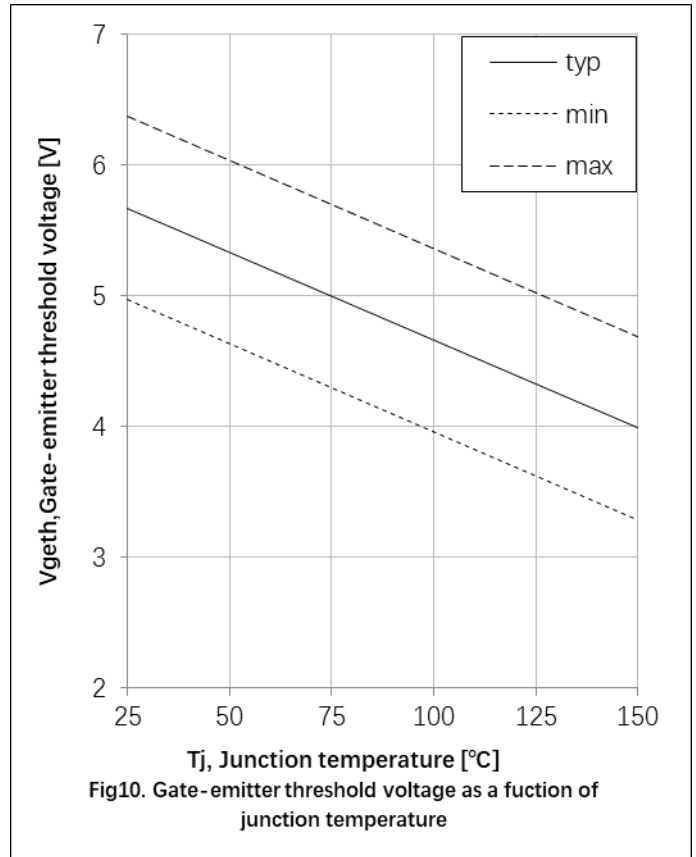
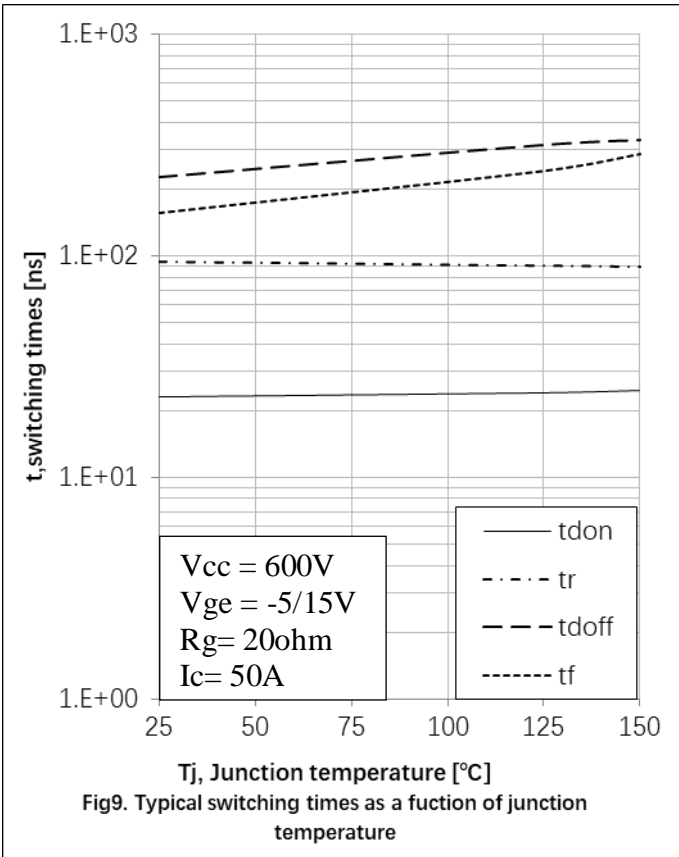

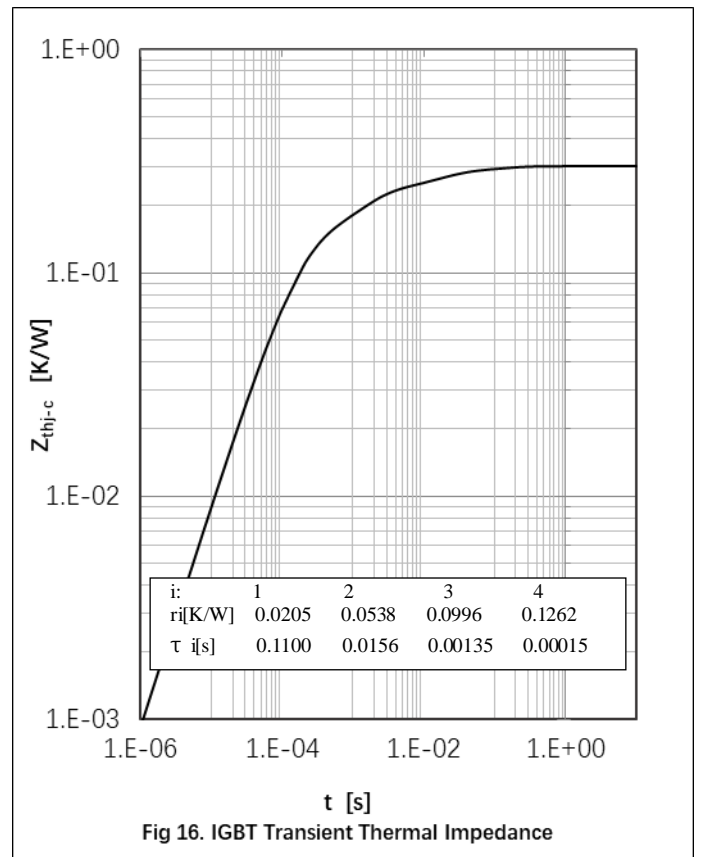
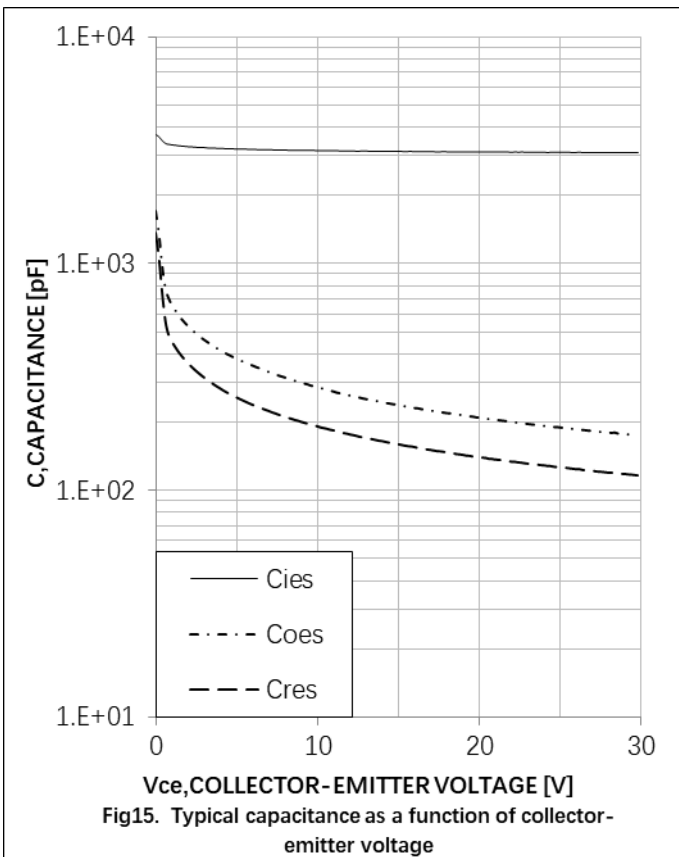
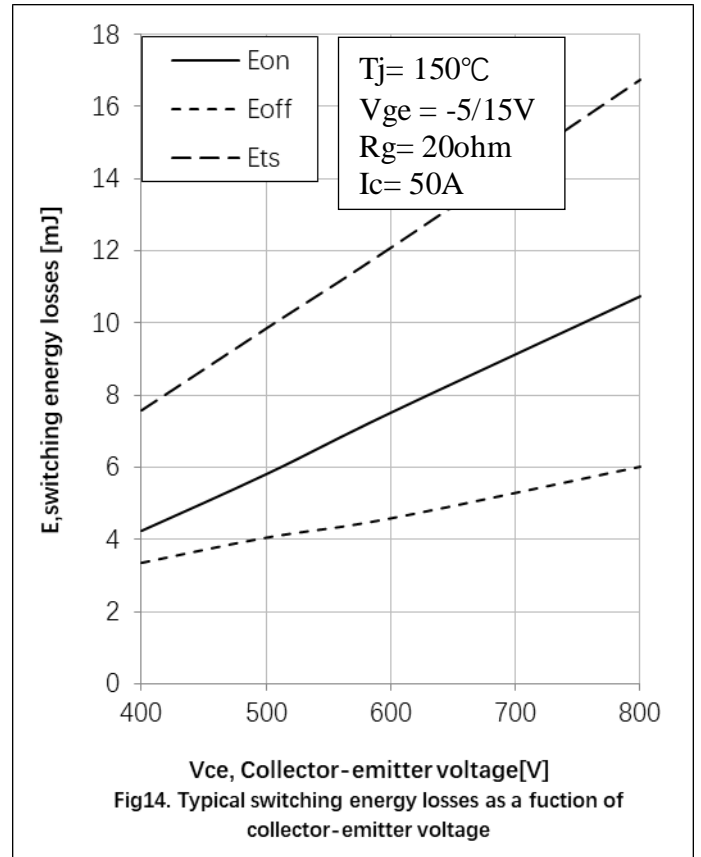
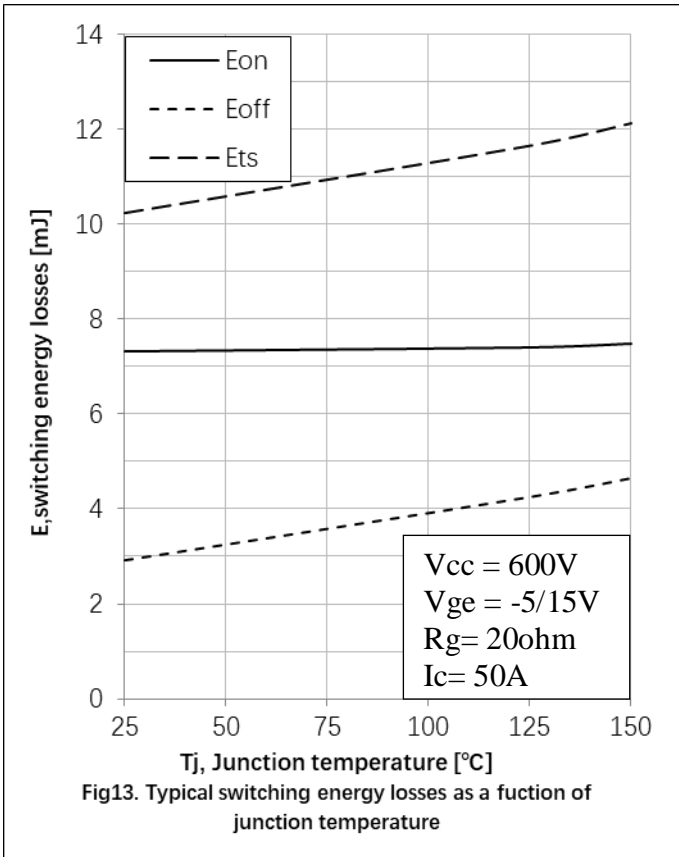

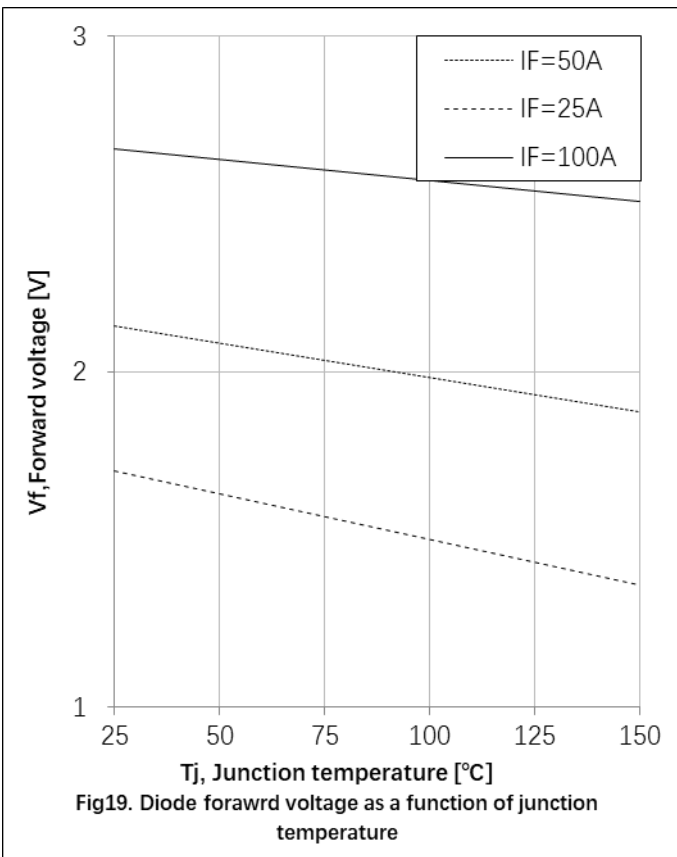
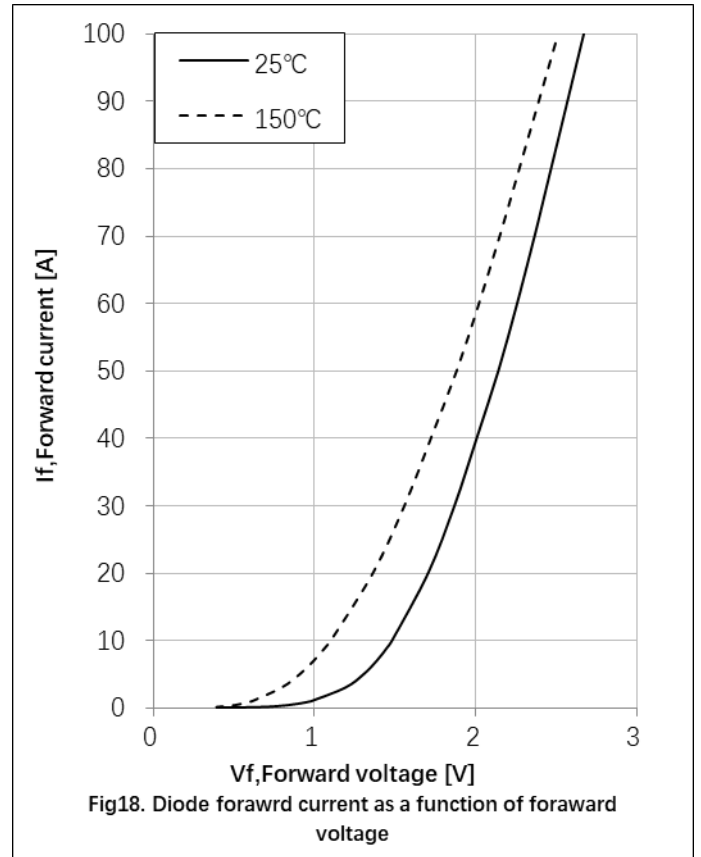
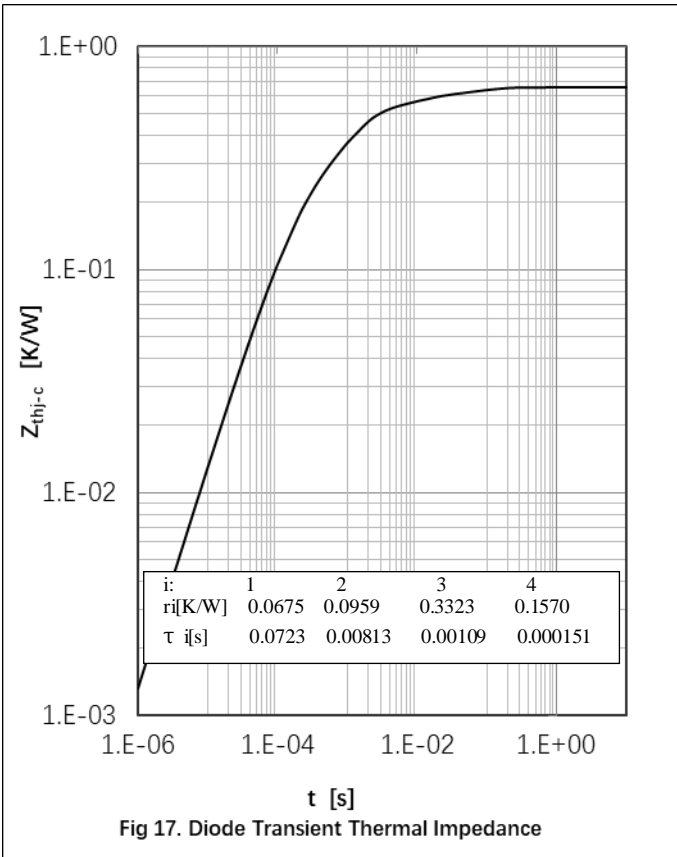

● Circuit Diagram

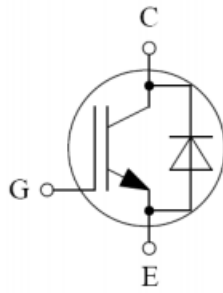

● Package Outline Information

CASE: TO 264

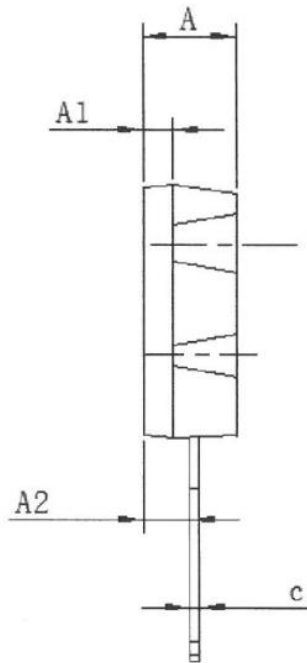
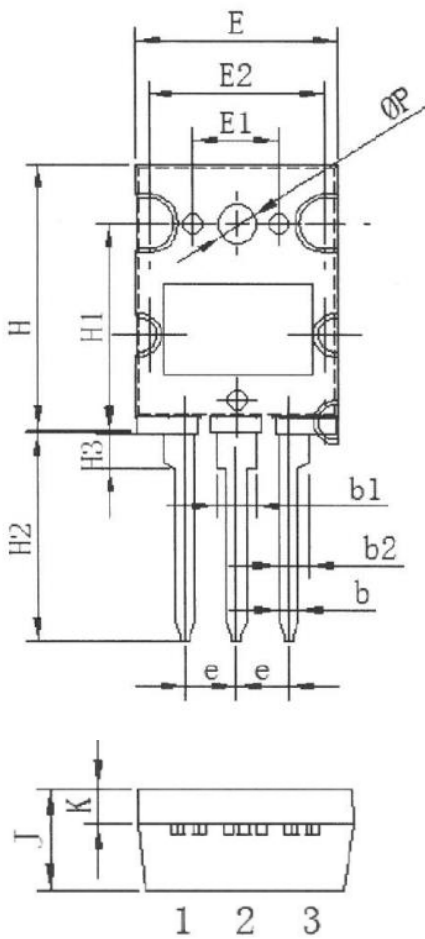

To-264		
Dim	Min	Max
A	4.80	5.20
A1	1.80	2.20
A2	3.20	3.60
b	0.80	1.20
b1	2.90	3.30
b2	2.40	2.80
C	0.50	0.70
e	5.25	5.65
E	19.8	20.2
E1	17.6	18.0
E2	8.60	9.00
H	25.8	26.2
H1	19.8	20.2
H2	19.8	20.8
H3	2.00	3.00
G	6.00	6.40
φP	3.00	3.40
J	4.80	5.20
K	1.30	1.70