

## IGBT Discrete

$V_{CE}$	<b>650</b>	<b>V</b>
$I_C$	<b>40</b>	<b>A</b>
$V_{CE(SAT)} I_C=40A$	<b>1.95</b>	<b>V</b>

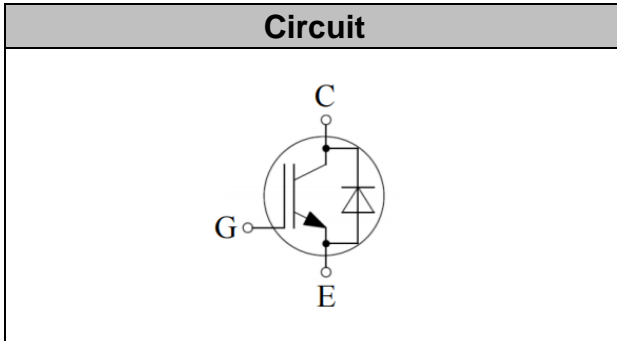

### Applications

- High frequency switching application
- Medical applications
- Uninterruptible power supply
- Motion/servo control

### Features

- Low switching losses
- Maximum junction temperature 175°C
- Positive temperature coefficient
- High ruggedness, temperature stable
- High short circuit capability(5us)

## Maximum Ratings

Parameter	Symbol	Value	Unit
Collector-Emitter Breakdown Voltage	$V_{CE}$	650	V
DC Collector Current, limited by $T_{jmax}$ $T_C=25^\circ C$ $T_C=100^\circ C$	$I_C$	80 40	A
Diode Forward Current, limited by $T_{jmax}$ $T_C=25^\circ C$ $T_C=100^\circ C$	$I_F$	60 30	A
Continuous Gate-Emitter Voltage	$V_{GE}$	$\pm 20$	V
Transient Gate-Emitter Voltage ( $t_p \leq 10\mu s, D < 0.010$ )	$V_{GE}$	$\pm 30$	V
Turn off Safe Operating Area $V_{CE} \leq 1200V,$ $T_j \leq 150^\circ C$		160	A
Pulsed Collector Current, $V_{GE}=15V,$ $t_p$ limited by $T_{jmax}$	$I_{CM}$	160	A
Diode Pulsed Current, $t_p$ limited by $T_{jmax}$	$I_{Fpuls}$	120	A
Short Circuit Withstand Time, $V_{GE}=15V, V_{CC}=400V, V_{CEM} \leq 650V$	$T_{sc}$	5	$\mu s$
Power Dissipation, $T_j=175^\circ C, T_C=25^\circ C$	$P_{tot}$	250	W

Operating Junction Temperature	$T_j$	-40...+175	°C
Storage Temperature	$T_s$	-55...+150	°C
Soldering Temperature, wave soldering 1.6mm (0.063in.) from case for 10s		260	°C

### Electrical Characteristics of the IGBT ( $T_j = 25^\circ\text{C}$ unless otherwise specified):

Parameter	Symbol	Conditions	Min.	Typ.	Max.	Unit
<b>Static</b>						
Collector-Emitter Breakdown Voltage	$BV_{CES}$	$V_{GE}=0V, I_C=250\mu A$	650		-	V
Gate Threshold Voltage	$V_{GE(th)}$	$V_{GE}=V_{CE}, I_C=0.64mA$	4.1	4.7	6.1	V
Collector-Emitter Saturation Voltage	$V_{CE(sat)}$	$V_{GE}=15V, I_C=40A$ $T_j=25^\circ\text{C}$ , $T_j=125^\circ\text{C}$ $T_j=150^\circ\text{C}$		1.95 2.30 2.40	2.40	V
Zero Gate Voltage Collector Current	$I_{CES}$	$V_{CE}=650V, V_{GE}=0V$ $T_j=25^\circ\text{C}$ , $T_j=150^\circ\text{C}$			0.25 4.00	mA
Gate-Emitter Leakage Current	$I_{GES}$	$V_{CE}=0V, V_{GE}=\pm 20V$			100	nA

Parameter	Symbol	Conditions	Min.	Typ.	Max.	Unit
<b>Dynamic</b>						
Input Capacitance	$C_{ies}$	$V_{CE}=25V, V_{GE}=0V,$ $f=1MHz$	-	1.56	-	nF
Reverse Transfer Capacitance	$C_{res}$		-	0.06	-	
Gate Charge	$Q_G$	$V_{CC}=300V, I_C=40A,$ $V_{GE}=15V$	-	0.16	-	uC
Short Circuit Collector Current	$I_{SC}$	$V_{GE}=15V, t_{sc}\leq 5\mu s,$ $V_{CC}=300V, T_j\leq 150^\circ\text{C}$	-	200	-	A

## Electrical Characteristics of the Diode (T<sub>j</sub>= 25°C unless otherwise specified):

Parameter	Symbol	Conditions	Min.	Typ.	Max.	Unit
<b>Static</b>						
Diode Forward Voltage	V <sub>F</sub>	I <sub>F</sub> = 30A T <sub>j</sub> = 25°C, T <sub>j</sub> = 125°C T <sub>j</sub> = 150°C		1.90 1.85 1.75	2.60	V

## Switching Characteristic, Inductive Load

Parameter	Symbol	Conditions	Min.	Typ.	Max.	Unit
<b>Dynamic , at T<sub>j</sub>= 25°C</b>						
Turn-on Delay Time	t <sub>d(on)</sub>	V <sub>CC</sub> =400V, I <sub>C</sub> =40A, V <sub>GE</sub> = 0V~15V, R <sub>g</sub> =10Ω,L <sub>s</sub> =60nH	-	12	-	ns
Rise Time	t <sub>r</sub>		-	31	-	ns
Turn-on Energy	E <sub>on</sub>		-	1.55	-	mJ
Turn-off Delay Time	t <sub>d(off)</sub>		-	124	-	ns
Fall Time	t <sub>f</sub>		-	54	-	ns
Turn-off Energy	E <sub>off</sub>		-	0.59	-	mJ
<b>Dynamic , at T<sub>j</sub>= 125°C</b>						
Turn-on Delay Time	t <sub>d(on)</sub>	V <sub>CC</sub> =400V, I <sub>C</sub> =40A, V <sub>GE</sub> = 0V~15V, R <sub>g</sub> =10Ω,L <sub>s</sub> =60nH	-	11	-	ns
Rise Time	t <sub>r</sub>		-	30	-	ns
Turn-on Energy	E <sub>on</sub>		-	1.57	-	mJ
Turn-off Delay Time	t <sub>d(off)</sub>		-	132	-	ns
Fall Time	t <sub>f</sub>		-	84	-	ns
Turn-off Energy	E <sub>off</sub>		-	0.83	-	mJ
<b>Dynamic , at T<sub>j</sub>= 150°C</b>						
Turn-on Delay Time	t <sub>d(on)</sub>	V <sub>CC</sub> =400V, I <sub>C</sub> =40A, V <sub>GE</sub> = 0V~15V, R <sub>g</sub> =10Ω,L <sub>s</sub> =60nH	-	11	-	ns
Rise Time	t <sub>r</sub>		-	30	-	ns
Turn-on Energy	E <sub>on</sub>		-	1.6	-	mJ
Turn-off Delay Time	t <sub>d(off)</sub>		-	137	-	ns
Fall Time	t <sub>f</sub>		-	102	-	ns
Turn-off Energy	E <sub>off</sub>		-	0.88	-	mJ

## Electrical Characteristics of the DIODE

Parameter	Symbol	Conditions	Min.	Typ.	Max.	Unit
<b>Dynamic , at T<sub>j</sub>= 25°C</b>						
Reverse Recovery Current	I <sub>rr</sub>	I <sub>F</sub> =30A, V <sub>R</sub> =400V di/dt= -350A/μs,	-	7	-	A
Reverse Recovery Charge	Q <sub>rr</sub>		-	0.14	-	uC
Diode reverse recovery time	t <sub>rr</sub>		-	42	-	ns
Reverse Recovery Energy	E <sub>rec</sub>		-	0.09	-	mJ
<b>Dynamic , at T<sub>j</sub>= 125°C</b>						
Reverse Recovery Current	I <sub>rr</sub>	I <sub>F</sub> =30A, V <sub>R</sub> =400V di/dt= -350A/μs,	-	13	-	A
Reverse Recovery Charge	Q <sub>rr</sub>		-	0.94	-	uC
Diode reverse recovery time	t <sub>rr</sub>		-	153	-	ns
Reverse Recovery Energy	E <sub>rec</sub>		-	0.22	-	mJ
<b>Dynamic , at T<sub>j</sub>= 150°C</b>						
Reverse Recovery Current	I <sub>rr</sub>	I <sub>F</sub> =30A, V <sub>R</sub> =400V di/dt= -350A/μs,	-	15	-	A
Reverse Recovery Charge	Q <sub>rr</sub>		-	1.26	-	uC
Diode reverse recovery time	t <sub>rr</sub>		-	161	-	ns
Reverse Recovery Energy	E <sub>rec</sub>		-	0.26	-	mJ

## Thermal Resistance

Parameter	Symbol	Max. Value	Unit
IGBT Thermal Resistance, Junction - Case	R <sub>th(j-c)</sub>	0.60	K/W
Diode Thermal Resistance, Junction - Case	R <sub>th(j-c)</sub>	1.05	K/W
Thermal Resistance, Junction - Ambient	R <sub>th(j-a)</sub>	40	K/W

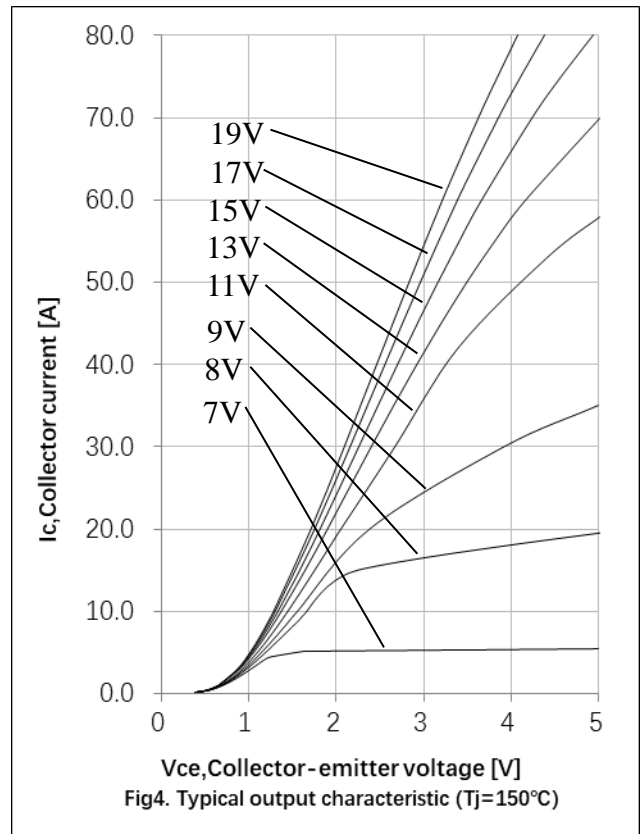
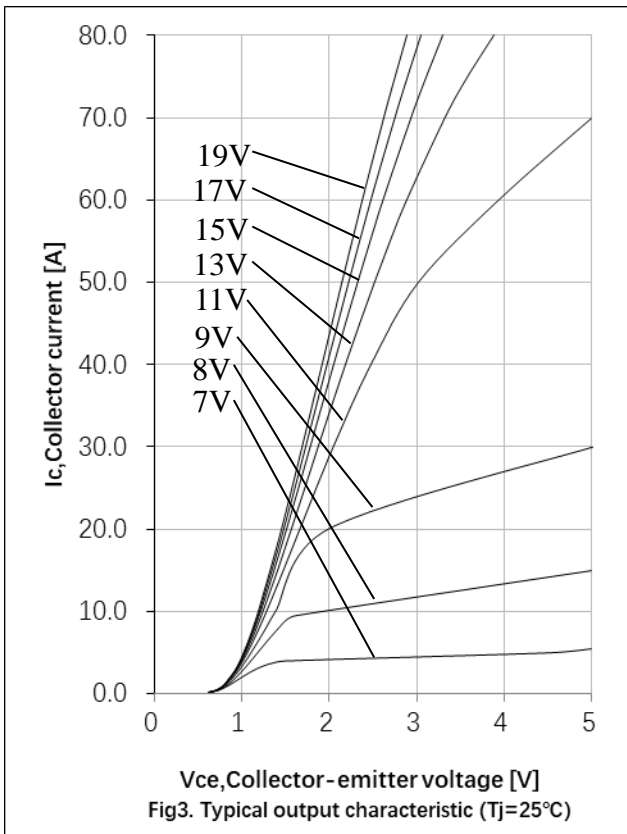
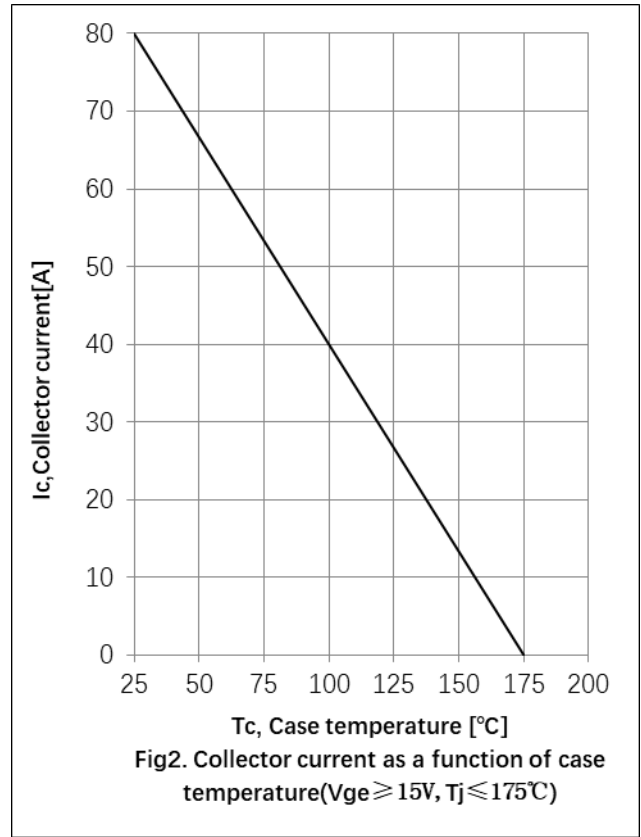
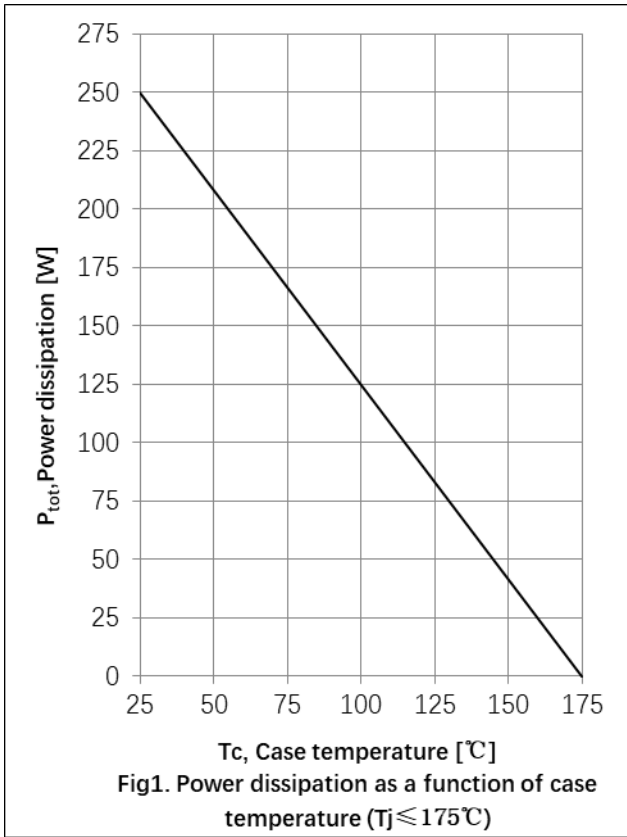

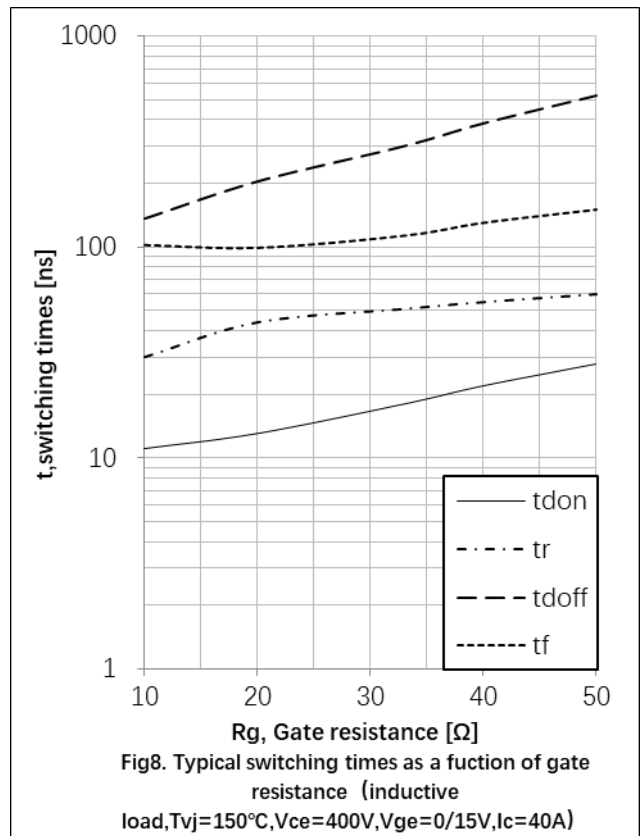
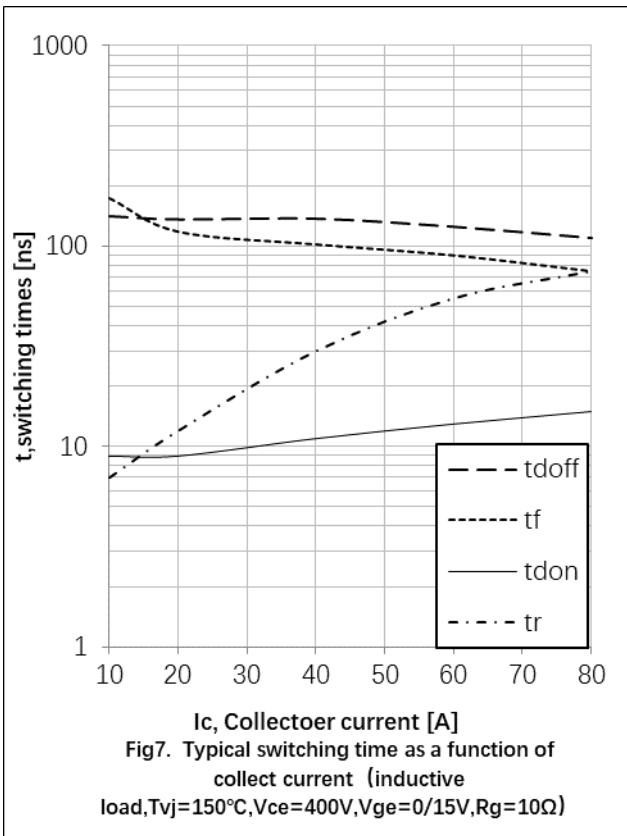
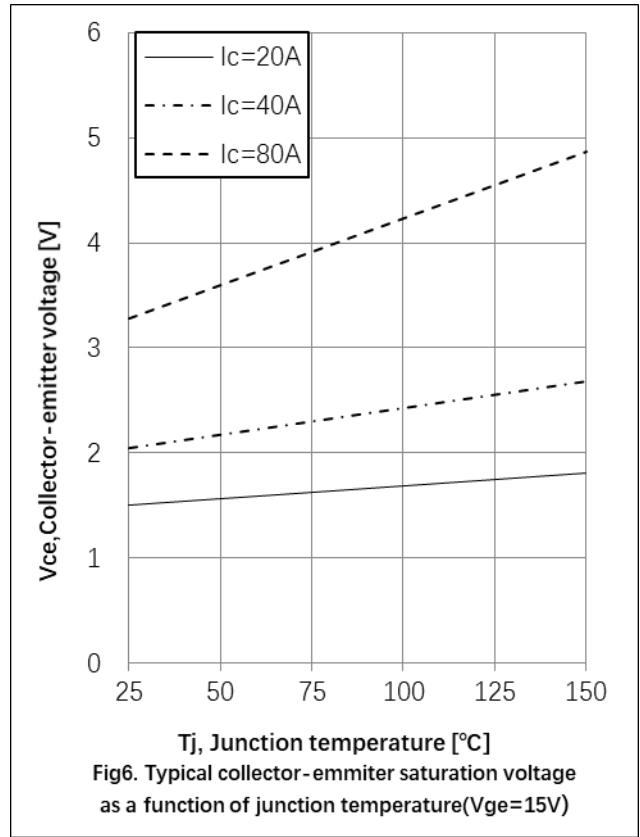
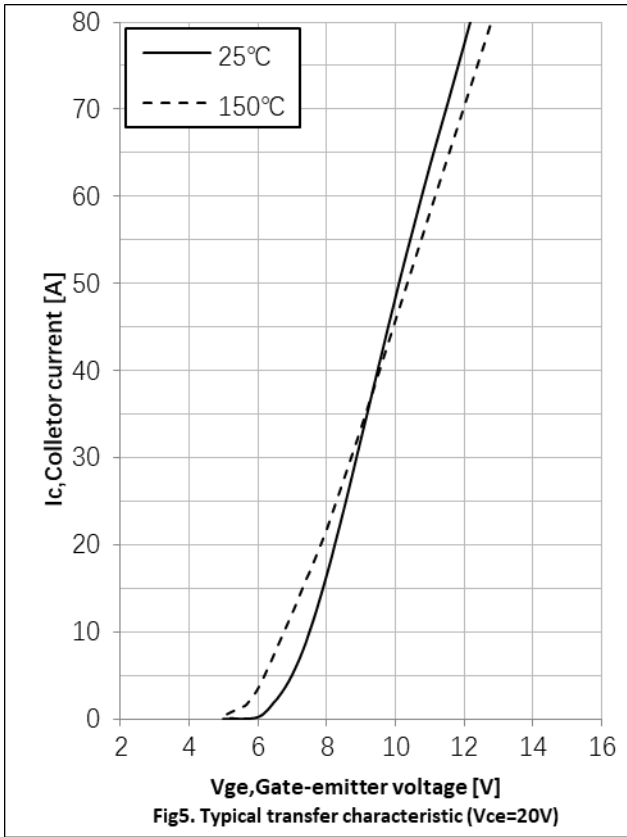

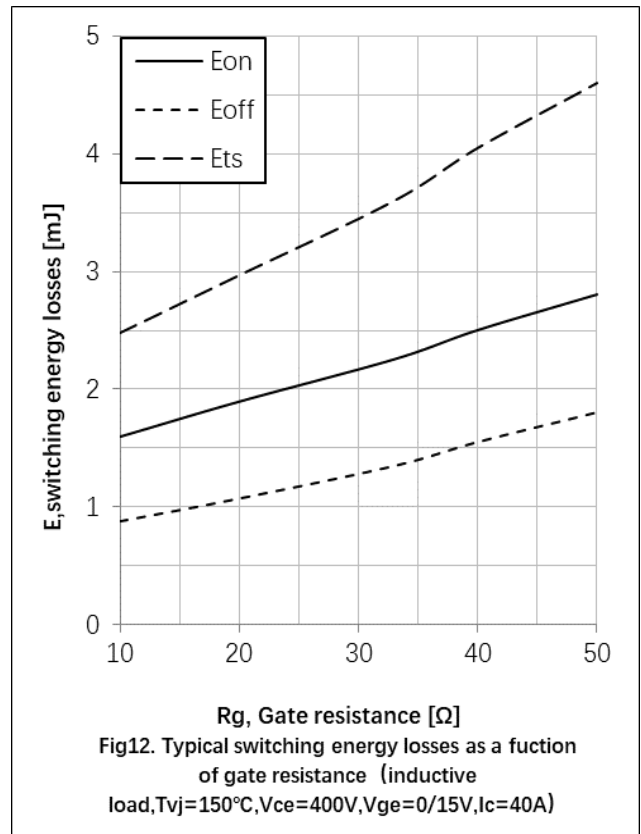
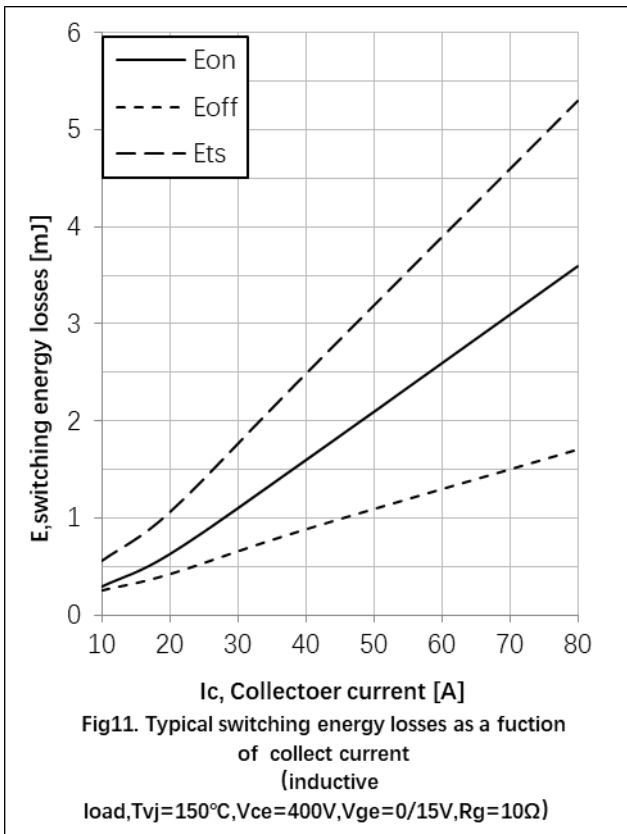
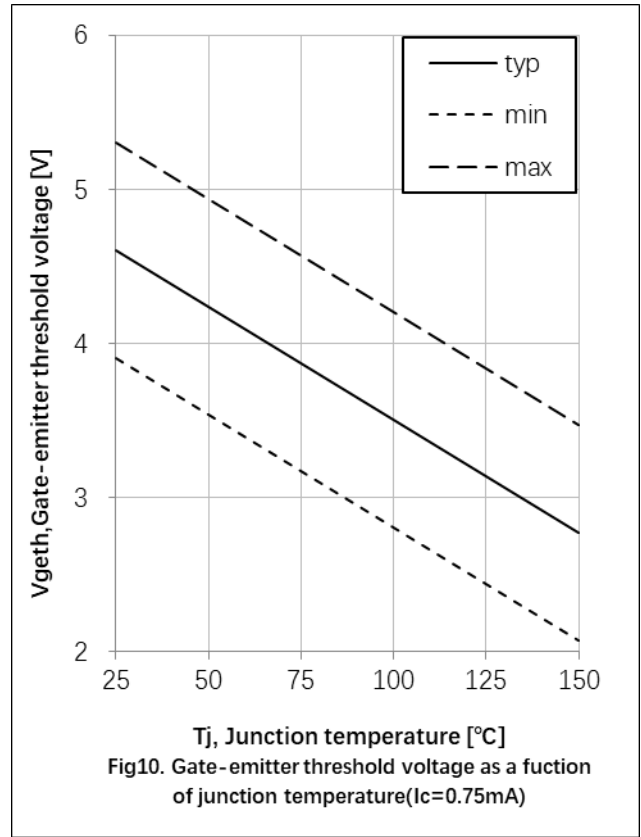
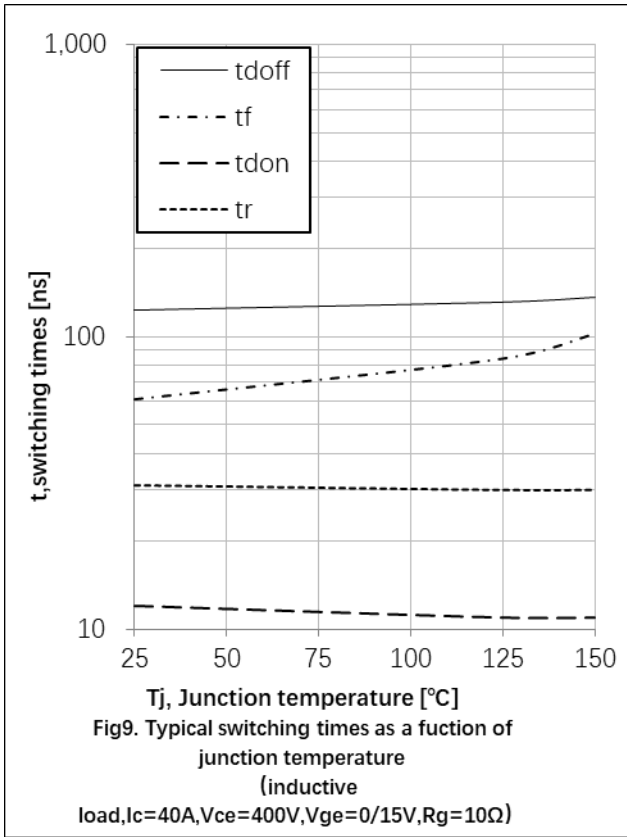

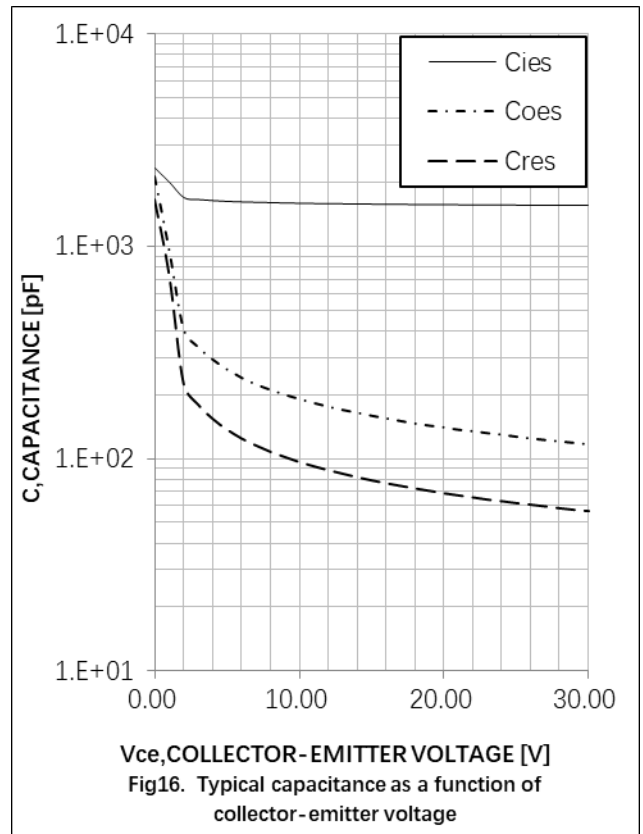
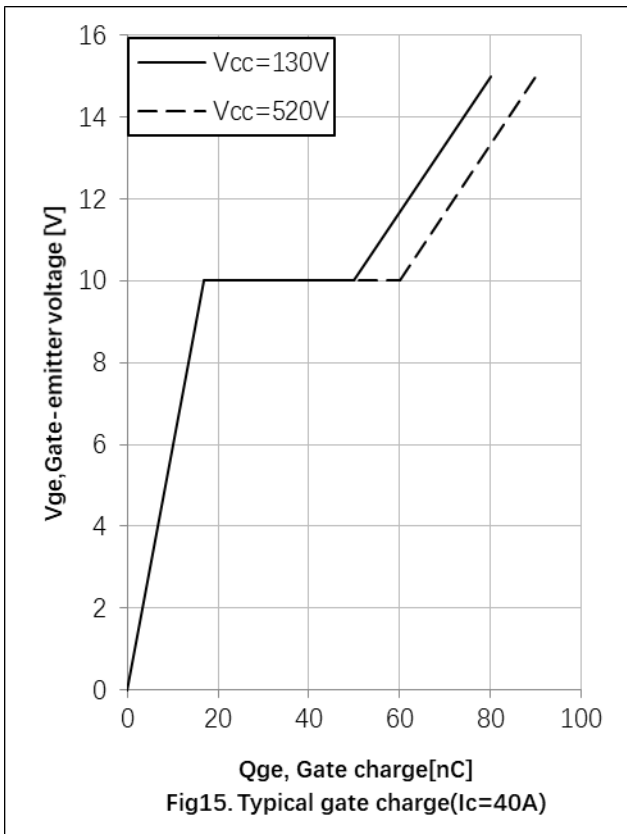
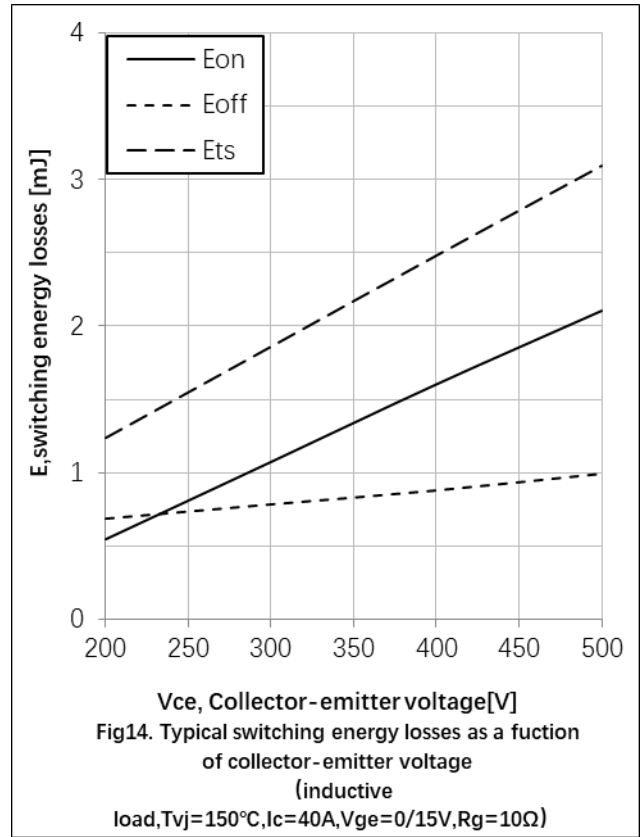
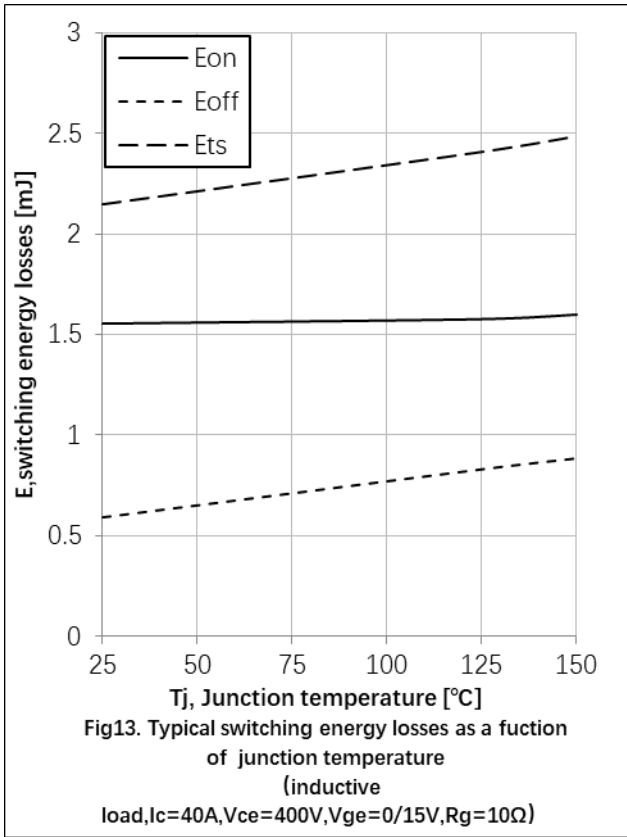

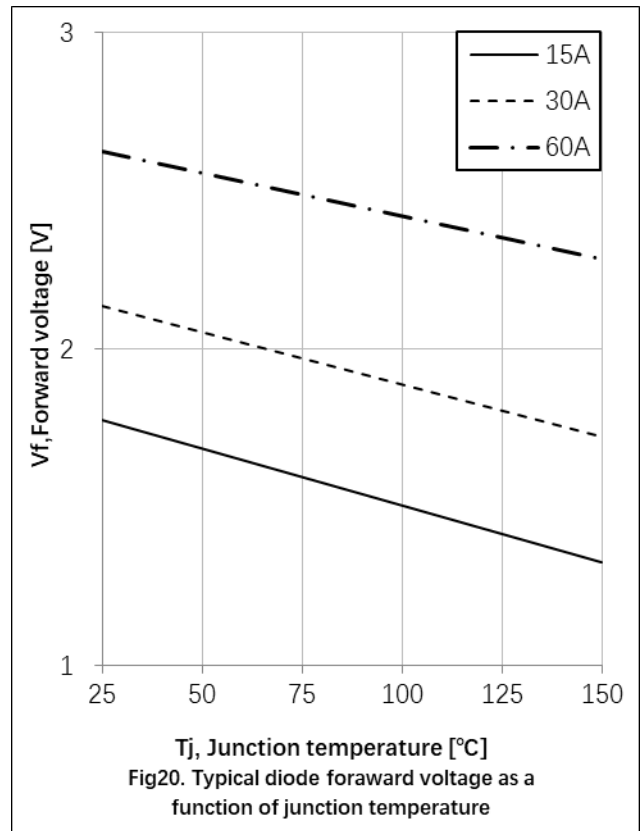
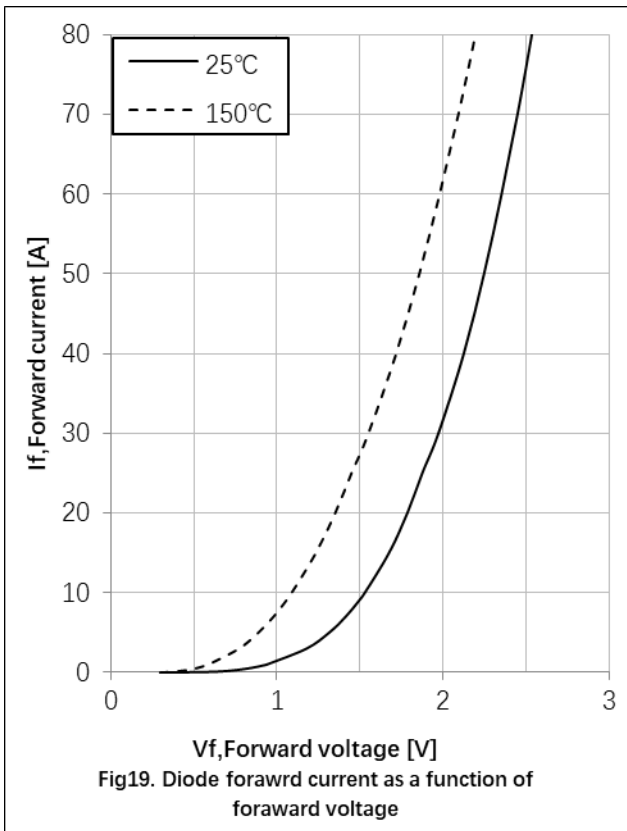
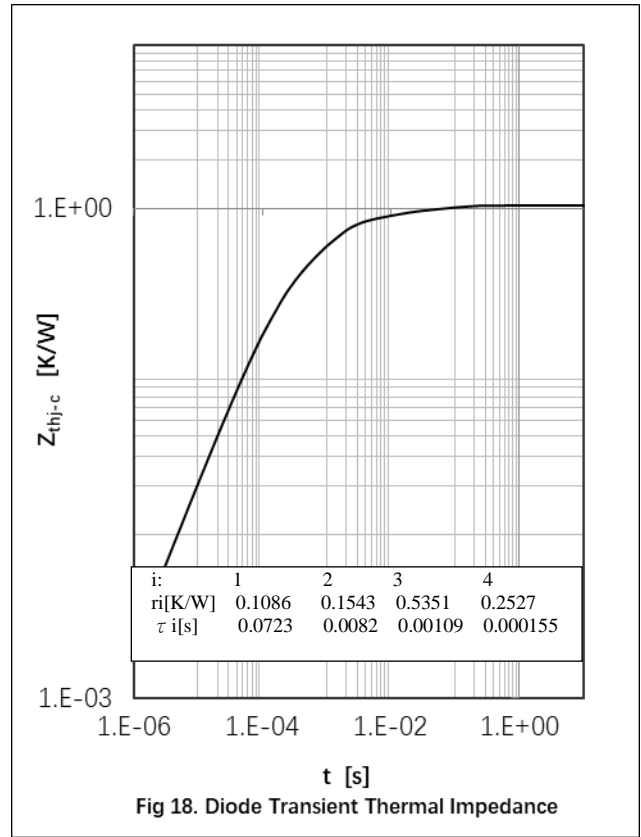
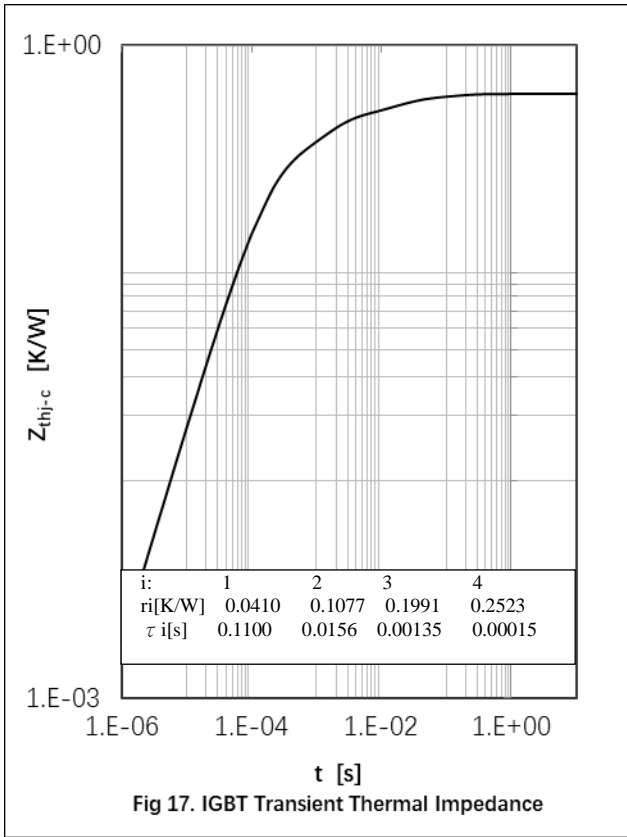

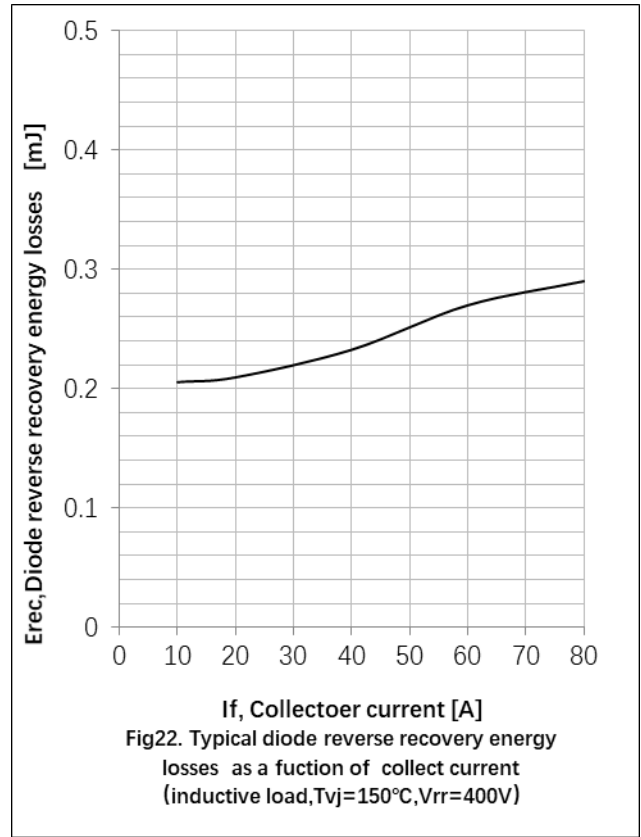
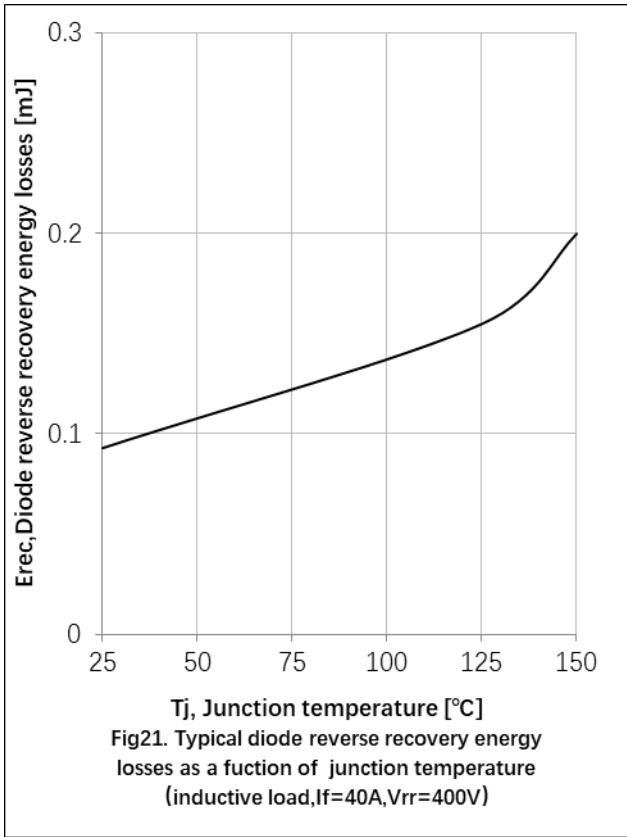

● Circuit Diagram

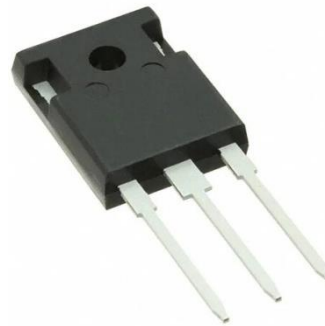
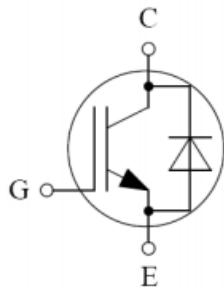

● Package Outline Information

CASE: TO 247

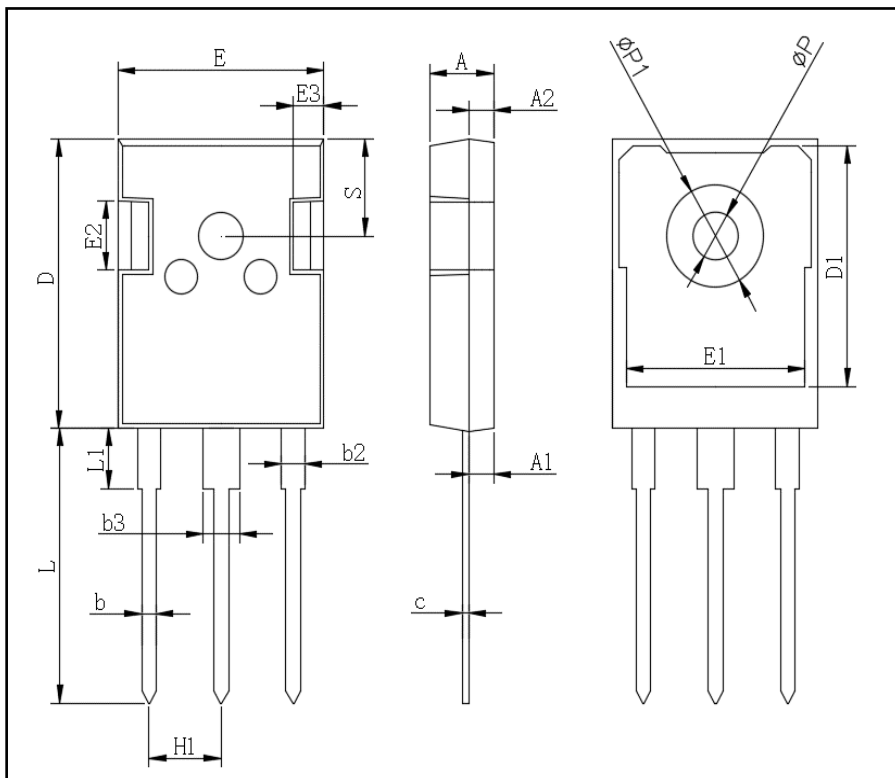

TO-247AB		
Dim	Min	Max
A	4.80	5.20
A1	2.21	2.61
A2	1.85	2.15
b	1.0	1.4
b2	1.91	2.21
C	0.5	0.7
D	20.70	21.30
D1	16.25	16.85
E	15.50	16.10
E1	13.0	13.6
E2	4.80	5.20
E3	2.30	2.70
L	19.62	20.22
L1	-	4.30
$\phi P$	3.40	3.80
$\phi P1$	-	7.30
S	6.15TYP	
H1	5.44TYP	
b3	2.80	3.20