

## SiC MOSFET Power Module



|              |               |
|--------------|---------------|
| $V_{DS}$     | 1200V         |
| $I_D$        | 440A          |
| $R_{DS(on)}$ | 3.2m $\Omega$ |

### Applications

- Induction Heating
- Motor Drives
- Solar and Wind Inverters
- UPS and SMPS

### Features

- Industry Standard 62mm Footprint
- Ultra Low Loss, High-Frequency Operation
- Zero Reverse Recovery from Diodes
- Zero Turn-off Tail Current from MOSFET
- Normally-off, Fail-safe Device Operation
- Copper Baseplate and Si<sub>3</sub>N<sub>4</sub> Insulator

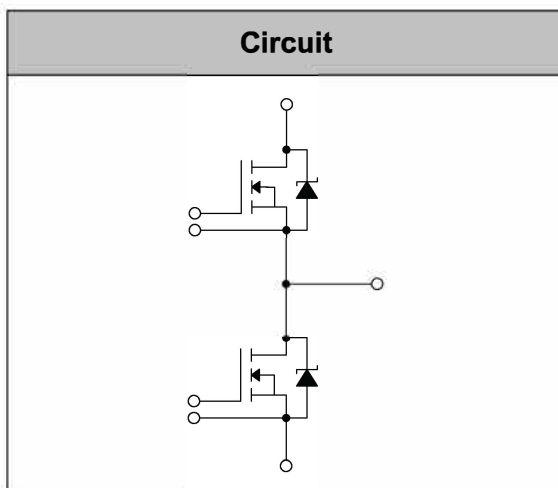

### ■ MOSFET

#### Absolute Maximum Ratings ( $T_{VJ}=25^{\circ}\text{C}$ Unless Otherwise Specified)

| PARAMETER                     | SYMBOL        | CONDITIONS                                     | VALUE  | UNIT               |
|-------------------------------|---------------|--|--------|--------------------|
| Drain-Source Voltage          | $V_{DS,max}$  | $V_{GS}=0\text{ V}$ , $I_{DS}=400\mu\text{A}$  | 1200   | V                  |
| Continuous Drain Current      | $I_D$         | $V_{GS}=18\text{V}$ , $T_C=25^{\circ}\text{C}$ | 440    | A                  |
|                               |               | $V_{GS}=18\text{V}$ , $T_C=80^{\circ}\text{C}$ | 355    |                    |
| Pulse Drain Current           | $I_{D,pulse}$ | Pulse width $t_p$ limited by $T_{VJ,max}$      | 890    | A                  |
| Power Dissipation             | $P_{D,MOS}$   | $T_C=25^{\circ}\text{C}$                       | 1400   | W                  |
| Recommend Gate Source Voltage | $V_{GS,op}$   | Static, recommended DC operating values        | -10/24 | V                  |
| Maximum Gate Source Voltage   | $V_{GS,max}$  | Absolute maximum values                        | -11/26 | V                  |
| Maximum Junction Temperature  | $T_{VJ,max}$  |  | 175    | $^{\circ}\text{C}$ |

**■ MOSFET**
**Characteristic Values ( $T_{VJ}=25^{\circ}\text{C}$  Unless Otherwise Specified)**

| PARAMETER  | SYMBOL        | CONDITIONS  | VALUE |       |      | UNIT                 |
|--|---------------|---|-------|-------|------|----------------------|
|  |               |   | Min.  | Typ.  | Max. |                      |
| Drain-Source Breakdown Voltage   | $V_{(BR)DSS}$ | $V_{GS}=0V, I_D=400\mu A$   | 1200  |       |      | V                    |
| Gate Threshold Voltage   | $V_{GS(th)}$  | $V_{DS}=V_{GS}, I_D=80mA$   | 1.9   | 3.0   | 4.7  | V                    |
|  |               | $V_{DS}=V_{GS}, I_D=80mA, T_{VJ}=175^{\circ}\text{C}$                         |       | 4.7   |      |                      |
| Zero Gate Voltage Drain Current  | $I_{DSS}$     | $V_{DS}=1200V, V_{GS}=0V$   |       | 4     | 300  | $\mu A$              |
| Gate-Source Leakage Current  | $I_{GSS}$     | $V_{DS}=0V, V_{GS}=18V$   |       | 1     | 400  | nA                   |
| Drain-Source On-Resistance   | $R_{DS(on)}$  | $I_D=300A, V_{GS}=15V$  |       |       | 6    | m $\Omega$           |
|  |               | $I_D=300A, V_{GS}=18V$  |       | 3.2   | 4.1  |                      |
|  |               | $I_D=300A, V_{GS}=15V, T_{VJ}=175^{\circ}\text{C}$                            |       |       |      |                      |
|  |               | $I_D=300A, V_{GS}=18V, T_{VJ}=175^{\circ}\text{C}$                            |       | 4.8   |      |                      |
| Transconductance   | $g_{fs}$      | $V_{DS}=20V, I_D=300A$  |       | 247.1 |      | S                    |
|  |               | $V_{DS}=20V, I_D=300A, T_{VJ}=175^{\circ}\text{C}$                            |       | 239.3 |      |                      |
| Internal Gate Resistance   | $R_{G(int.)}$ | $f=1MHz, V_{AC}=25mV$   |       | 0.12  |      | $\Omega$             |
| Input Capacitance  | $C_{iss}$     | $V_{GS}=0V,$  |       | 25.1  |      | nF                   |
| Output Capacitance   | $C_{oss}$     | $V_{DS}=800V,$<br>$f=100kHz,$   |       | 1.2   |      |                      |
| Reverse Transfer Capacitance   | $C_{rss}$     | $V_{AC}=25mV$   |       | 0.02  |      |                      |
| Gate to Source Charge  | $Q_{GS}$      | $V_{DD}=800V,$<br>$V_{GS}=-5/18V,$<br>$I_D=300A$                              |       | 224   |      | nC                   |
| Gate to Drain Charge   | $Q_{GD}$      |   |       | 440   |      |                      |
| Total Gate Charge  | $Q_G$         |   |       | 940   |      |                      |
| Turn On Delay Time   | $t_{d(on)}$   | $V_{DS}=800V,$<br>$V_{GS}=-3/18V,$<br>$I_D=240A,$<br>$R_{G(ext)}=2.7\ \Omega$ |       | 20    |      | ns                   |
| Rise Time  | $t_r$         |   |       | 34    |      |                      |
| Turn Off Delay Time  | $t_{d(off)}$  |   |       | 48    |      |                      |
| Fall Time  | $t_f$         |   |       | 15    |      |                      |
| Turn-on Switching Energy, $T_{VJ}=25^{\circ}\text{C}$<br>$T_{VJ}=175^{\circ}\text{C}$  | $E_{on}$      |   |       |       | 3.5  | mJ                   |
|  |               |   |       |       | 4.52 |                      |
| Turn-off Switching Energy, $T_{VJ}=25^{\circ}\text{C}$<br>$T_{VJ}=175^{\circ}\text{C}$ | $E_{off}$     |   |       |       | 1.38 | mJ                   |
|  |               |   |       | 1.87  |      |                      |
| MOSFET Thermal Resistance,<br>Junction to Case   | $R_{thJC}$    | JESD51-14   |       | 0.095 |      | $^{\circ}\text{C/W}$ |

# MC045HF12SCC2

## ■ Body diode

Characteristic Values ( $T_{VJ}=25^{\circ}\text{C}$  Unless Otherwise Specified)

| PARAMETER  | SYMBOL   | CONDITIONS   | VALUE |              |      | UNIT          |
|--|----------|--|-------|--------------|------|---------------|
|  |          |  | Min.  | Typ.         | Max. |               |
| Inverse Diode Forward Voltage  | $V_{SD}$ | $V_{GS}=0V, I_S=240A$  |       | 3.51         |      | V             |
|  |          | $V_{GS}=0V, I_S=240A, T_{VJ}=175^{\circ}\text{C}$                                |       | 3.2          |      |               |
| Continuous Diode Forward Current   | $I_S$    | $V_{GS}=0V, T_c=25^{\circ}\text{C}$  |       |              | 430  | A             |
| Reverse Recovery Time  | $t_{rr}$ | $V_{GS}=-3V, I_S=240A, V_R=800V,$<br>$di/dt=4.63A/ns, T_{VJ}=25^{\circ}\text{C}$ |       | 20           |      | ns            |
| Reverse Recovery Charge  | $Q_{rr}$ |  |       | 2.27         |      | $\mu\text{C}$ |
| Peak Reverse Recovery Current  | $I_{rm}$ |  |       | 197.8        |      | A             |
| Reverse Recovery Energy, $T_{VJ}=25^{\circ}\text{C}$<br>$T_{VJ}=150^{\circ}\text{C}$ | $E_{RR}$ | $V_{DD}=600V, I_D=300A$<br>$V_{GS}=-3V/18V, R_{G(ext)}=2.7\Omega$                |       | 0.83<br>1.01 |      | mJ            |

## ■ Module Characteristics

| PARAMETER                      | SYMBOL      | CONDITIONS                            | VALUE |      |      | UNIT               |
|--------------------------------|-------------|---------------------------------------|-------|------|------|--------------------|
|                                |             |                                       | Min.  | Typ. | Max. |                    |
| Isolation Breakdown Voltage    | $V_{isol}$  | AC, 50Hz (R.M.S), $t=1\text{minute}$  |       | 4000 |      | V                  |
| Stray Inductance               | $L_{stray}$ | Between DC- and DC+, $f=10\text{MHz}$ |       | 11   |      | nH                 |
| Operating Junction Temperature | $T_{VJ,op}$ |                                       | -40   |      | 175  | $^{\circ}\text{C}$ |
| Storage Temperature            | $T_{stg}$   |                                       | -40   |      | 125  | $^{\circ}\text{C}$ |
| Module Electrodes Torque       | $M_t$       | Recommended (M6)                      | 3.0   |      | 6.0  | Nm                 |
| Module to Sink Torque          | $M_s$       | Recommended (M6)                      | 3.0   |      | 6.0  | Nm                 |
| Weight                         | $W$         |                                       |       | 340  |      | g                  |

■ Schematic and Pin Out

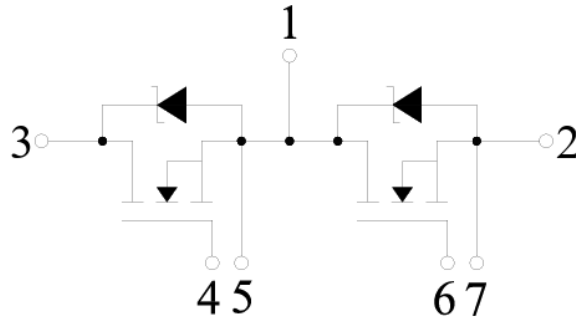

■ Package Dimensions (mm)

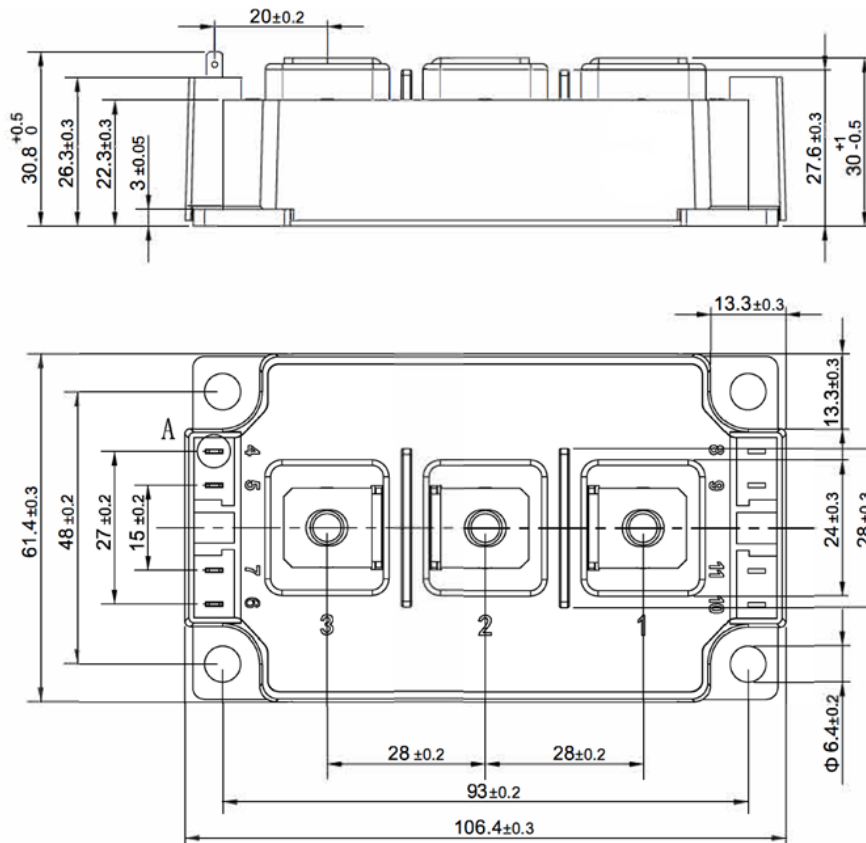

View A  
scale 3:1

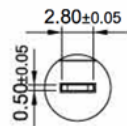

### **Disclaimer**

The information presented in this document is for reference only. Shanghai Sunco Electronics Co., Ltd reserves the right to make changes without notice for the specification of the products displayed herein to improve reliability, function or design or otherwise.

The product listed herein is designed to be used with ordinary electronic equipment or devices, and not designed to be used with equipment or devices which require high level of reliability and the malfunction of which would directly endanger human life (such as medical instruments, transportation equipment, aerospace machinery, nuclear-reactor controllers, fuel controllers and other safety devices), Russiansunco or anyone on its behalf, assumes no responsibility or liability for any damages resulting from such improper use of sale.

This publication supersedes & replaces all information previously supplied. For additional information, please visit our website [http:// www.russiansunco.com](http://www.russiansunco.com) , or consult your nearest Russiansunco's sales office for further assistance